



SGM3157

4.5Ω Low Voltage SPDT Analog Switch in 6-pin SC70

GENERAL DESCRIPTION

The SGM3157 is a single, bidirectional, single-pole/double-throw (SPDT) CMOS analog switch that is designed to operate from a single +1.8V to +5.5V supply. It features high-bandwidth (300MHz) and low on-resistance (4.5Ω TYP), Targeted applications for audio switching.

SGM3157 features guaranteed on-resistance matching (0.3Ω MAX) between switches and guaranteed on-resistance flatness over the signal range (2.3Ω TYP). This ensures excellent linearity and low distortion when switching audio signals.

SGM3157 is available in a SC70-6 package.

FEATURES

- Voltage Operation: 1.8V to 5.5V
- On-Resistance: 4.5Ω (TYP) at 5.0V
- Fast Switching Times
 - t_{ON} 20ns
 - t_{OFF} 15ns
- High Bandwidth: 300MHz
- High Off-Isolation: -51dB at 10MHz
- Rail-to-Rail Operation
- TTL/CMOS Compatible
- Break-Before-Make Switching
- Extended Industrial Temperature Range: -40°C to 85°C
- Lead (Pb) Free SC70-6 Package

APPLICATIONS

- Portable Instrumentation
- Battery-Operated Equipment
- Computer Peripherals
- Cell Phones
- PDA's
- MP3's

FUNCTION TABLE

LOGIC	NO	NC
0	OFF	ON
1	ON	OFF

Switches Shown for Logic "0" Input

PIN CONFIGURATION (TOP VIEW)

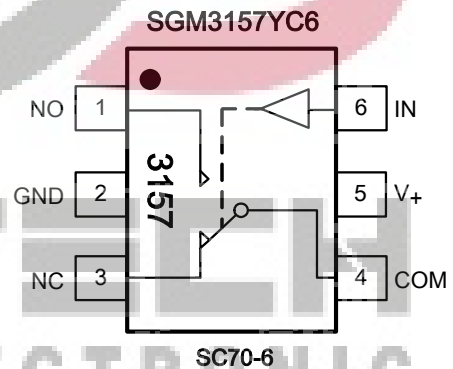

ORDERING INFORMATION

MODEL	PIN-PACKAGE	SPECIFIED TEMPERATURE RANGE	ORDERING NUMBER	PACKAGE MARKING	PACKAGE OPTION
SGM3157	SC70-6	-40°C to +85°C	SGM3157YC6/TR	3157	Tape and Reel, 3000

Note: SC70-6 package is same as SOT-363 package.

ABSOLUTE MAXIMUM RATINGS

V+, IN to GND.....	-0.3V to 6V	Junction Temperature.....	150°C
Analog, Digital voltage range ⁽¹⁾	-0.3V to (V ₊) + 0.3V	Storage Temperature.....	-65°C to +150°C
Continuous Current NO, NC, or COM.....	±50mA	Lead Temperature (soldering, 10s).....	260°C
Peak Current NO, NC, or COM.....	±80mA	ESD (HBM).....	2000V
Operating Temperature Range.....	-40°C to +85°C	ESD (MM).....	400V

Stresses beyond those listed under “Absolute Maximum Ratings” may cause permanent damage to the device. These are stress ratings only, and functional operation of the device at these or any other conditions beyond those indicated in the operational sections of the specifications is not implied. Exposure to absolute maximum rating conditions for extended periods may affect device reliability. (1) Signals on NC, NO, or COM or IN exceeding V₊ will be clamped by internal diodes. Limit forward diode current to maximum current ratings.

CAUTION

This integrated circuit can be damaged by ESD if you don't pay attention to ESD protection. SGMICRO recommends that all integrated circuits be handled with appropriate precautions. Failure to observe proper handling and installation procedures can cause damage.

ESD damage can range from subtle performance degradation to complete device failure. Precision integrated circuits may be more susceptible to damage because very small parametric changes could cause the device not to meet its published specifications.

PIN DESCRIPTION

NAME	PIN	FUNCTION
NO	1	Normally-open terminal
GND	2	Ground
NC	3	Normally-closed terminal
COM	4	Common terminal
V ₊	5	Power supply
IN	6	Digital control pin to connect the COM terminal to the NO or NC terminals

Note: NO, NC and COM terminals may be an input or output.

ELECTRICAL CHARACTERISTICS

(V₊ = +4.5V to +5.5V, V_{IH} = +2.0V, V_{IL} = +0.8V, T_A = -40°C to +85°C, Typical values are at V₊ = 5.0V, T_A = +25°C, unless otherwise noted.)

PARAMETER	SYMBOL	CONDITIONS	TEMP	MIN	TYP	MAX	UNITS
ANALOG SWITCH							
Analog Signal Range	V _{NO} , V _{NC} , V _{COM}		-40°C to +85°C	0		V ₊	V
On-Resistance	R _{ON}	V ₊ = 4.5V, V _{NO} or V _{NC} = 3.5V, I _{COM} = -10mA, Test Circuit 1	+25°C		4.5	8	Ω
			-40°C to +85°C			8.5	Ω
On-Resistance Match Between Channels	ΔR _{ON}	V ₊ = 4.5V, V _{NO} or V _{NC} = 3.5V, I _{COM} = -10mA, Test Circuit 1	+25°C		0.15	0.3	Ω
			-40°C to +85°C			0.4	Ω
On-Resistance Flatness	R _{FLAT(ON)}	V ₊ = 4.5V, V _{NO} or V _{NC} = 1.0V, 2.0V, 3.5V, I _{COM} = -10mA, Test Circuit 1	+25°C		2.3	3.3	Ω
			-40°C to +85°C			3.7	Ω
Source OFF Leakage Current	I _{NC(OFF)} , I _{NO(OFF)}	V ₊ = 5.5V, V _{NO} or V _{NC} = 1.0V, 4.5V, V _{COM} = 4.5V, 1.0V	-40°C to +85°C			1	μA
Channel ON Leakage Current	I _{NC(ON)} , I _{NO(ON)} , I _{COM(ON)}	V ₊ = 5.5V, V _{COM} = 1.0V, 4.5V, V _{NO} or V _{NC} = 1.0V, 4.5V, or floating	-40°C to +85°C			1	μA
DIGITAL INPUTS							
Input High Voltage	V _{IINH}		-40°C to +85°C	1.5			V
Input Low Voltage	V _{INL}		-40°C to +85°C			0.6	V
Input Leakage Current	I _{IN}	V ₊ = +5.5V, V _{IN} = 0V or 5.5V	-40°C to +85°C			1	μA
DYNAMIC CHARACTERISTICS							
Turn-On Time	t _{ON}	V _{NO} or V _{NC} = 3.0V, V _{IH} = 1.5V, V _{IL} = 0V, R _L = 300Ω, C _L = 35pF, Test Circuit 2	+25°C		20		ns
Turn-Off Time	t _{OFF}	V _{NO} or V _{NC} = 3.0V, V _{IH} = 1.5V, V _{IL} = 0V, R _L = 300Ω, C _L = 35pF, Test Circuit 2	+25°C		15		ns
Break-Before-Make Time Delay	t _D	V _{NO1} or V _{NC1} = V _{NO2} or V _{NC2} = 3V, R _L = 300Ω, C _L = 35pF, Test Circuit 3	+25°C		5		ns
Skew	t _{SKEW}	R _S = 39Ω, C _L = 50pF, Test Circuit 4	+25°C		5		ns
Off Isolation	O _{ISO}	R _L = 50Ω, C _L = 5pF, Signal = 0dBm, Test Circuit 5	f = 10MHz	+25°C		-51	dB
			f = 1MHz	+25°C		-72	dB
-3dB Bandwidth	BW	Signal = 0dBm, R _L = 50Ω, C _L = 5pF, Test Circuit 6	+25°C		300		MHz
Source OFF Capacitance	C _{NC(OFF)} , C _{NO(OFF)}	f = 1MHz	+25°C		5.5		pF
Channel ON Capacitance	C _{NC(ON)} , C _{NO(ON)} , C _{COM(ON)}	f = 1MHz	+25°C		15.5		pF
POWER REQUIREMENTS							
Power Supply Range	V ₊		-40°C to +85°C	1.8		5.5	V
Power Supply Current	I ₊	V ₊ = +5.5V, V _{IN} = 0V or V ₊	-40°C to +85°C			5	μA

Specifications subject to change without notice.



ELECTRICAL CHARACTERISTICS

(V₊ = +2.7V to +3.6V, V_{IH} = +1.4V, V_{IL} = +0.5V, T_A = -40°C to +85°C, Typical values are at V₊ = 3.0V, T_A = +25°C, unless otherwise noted.)

PARAMETER	SYMBOL	CONDITIONS	TEMP	MIN	TYP	MAX	UNITS
ANALOG SWITCH							
Analog Signal Range	V _{NO} , V _{NC} , V _{COM}		-40°C to +85°C	0		V ₊	V
On-Resistance	R _{ON}	V ₊ = 2.7V, V _{NO} or V _{NC} = 1.5V, I _{COM} = -10mA, Test Circuit 1	+25°C		7	10	Ω
			-40°C to +85°C			10.5	Ω
On-Resistance Match Between Channels	ΔR _{ON}	V ₊ = 2.7V, V _{NO} or V _{NC} = 1.5V, I _{COM} = -10mA, Test Circuit 1	+25°C		0.15	0.3	Ω
			-40°C to +85°C			0.4	Ω
On-Resistance Flatness	R _{FLAT(ON)}	V ₊ = 2.7V, V _{NO} or V _{NC} = 1.0V, 1.5V, 2.0V, I _{COM} = -10mA, Test Circuit 1	+25°C		3	4	Ω
			-40°C to +85°C			4.3	Ω
Source OFF Leakage Current	I _{NC(OFF)} , I _{NO(OFF)}	V ₊ = 3.6V, V _{NO} or V _{NC} = 0.3V, 3.3V, V _{COM} = 3.3V, 0.3V,	-40°C to +85°C			1	μA
Channel ON Leakage Current	I _{NC(ON)} , I _{NO(ON)} , I _{COM(ON)}	V ₊ = 3.6V, V _{COM} = 0.3V, 3.3V, V _{NO} or V _{NC} = 0.3V, 3.3V, or floating	-40°C to +85°C			1	μA
DIGITAL INPUTS							
Input High Voltage	V _{INH}		-40°C to +85°C	1			V
Input Low Voltage	V _{INL}		-40°C to +85°C			0.5	V
Input Leakage Current	I _{IN}	V ₊ = +5.5V, V _{IN} = 0V or 3.6V	-40°C to +85°C			1	μA
DYNAMIC CHARACTERISTICS							
Turn-On Time	t _{ON}	V _{NO} or V _{NC} = 1.5V, V _{IH} = 1.5V, V _{IL} = 0V, R _L = 300Ω, C _L = 35pF, Test Circuit 2	+25°C		30		ns
Turn-Off Time	t _{OFF}	V _{NO} or V _{NC} = 1.5V, V _{IH} = 1.5V, V _{IL} = 0V, R _L = 300Ω, C _L = 35pF, Test Circuit 2	+25°C		25		ns
Break-Before-Make Time Delay	t _D	V _{NO1} or V _{NC1} = V _{NO2} or V _{NC2} = 3V, R _L = 300Ω, C _L = 35pF, Test Circuit 3	+25°C		8		ns
Skew	t _{SKREW}	R _S = 39Ω, C _L = 50pF, Test Circuit 4	+25°C		2		ns
Off Isolation	O _{ISO}	R _L = 50Ω, C _L = 5pF, Signal = 0dBm, Test Circuit 5	f = 10MHz	+25°C		-51	dB
			f = 1MHz	+25°C		-72	dB
-3dB Bandwidth	BW	Signal = 0dBm, R _L = 50Ω, C _L = 5pF, Test Circuit 6	+25°C		300		MHz
Source OFF Capacitance	C _{NC(OFF)} , C _{NO(OFF)}	f = 1MHz	+25°C		5.5		pF
Channel ON Capacitance	C _{NC(ON)} , C _{NO(ON)} , C _{COM(ON)}	f = 1MHz	+25°C		15.5		pF
POWER REQUIREMENTS							
Power Supply Range	V ₊		-40°C to +85°C	1.8		5.5	V
Power Supply Current	I ₊	V ₊ = +5.5V, V _{IN} = 0V or V ₊	-40°C to +85°C			5	μA

Specifications subject to change without notice.



TYPICAL PERFORMANCE CHARACTERISTICS

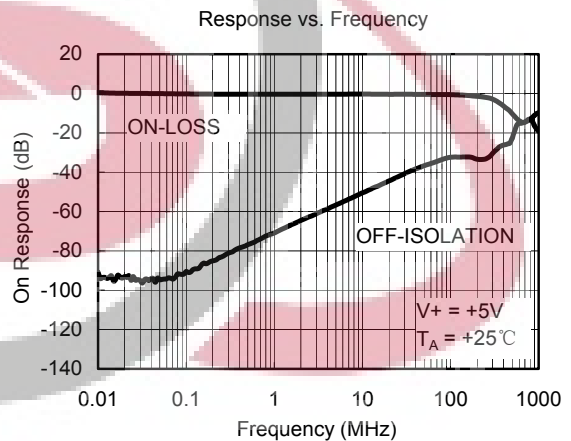
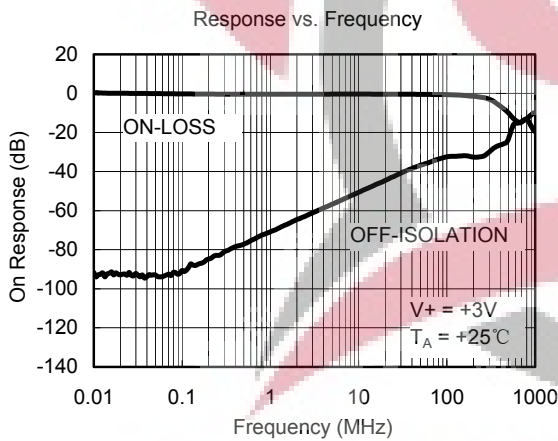
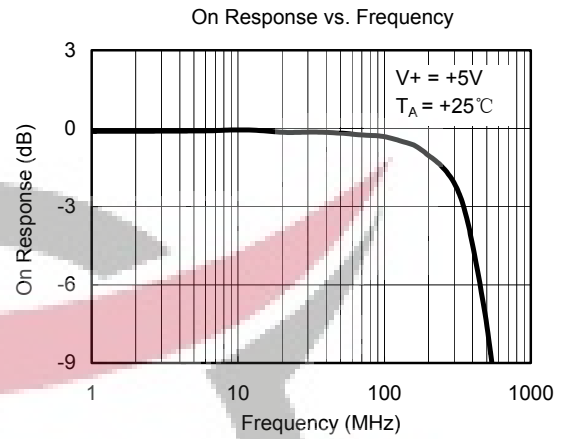
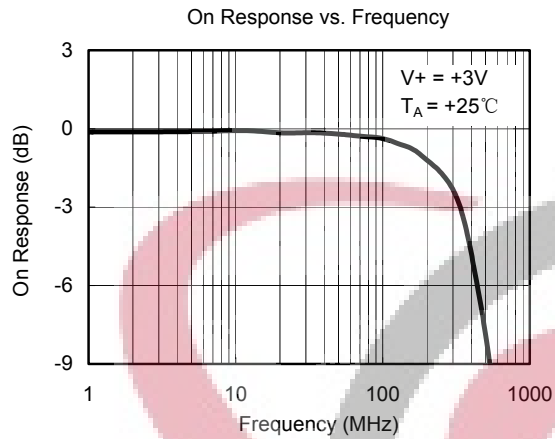

TEST CIRCUITS

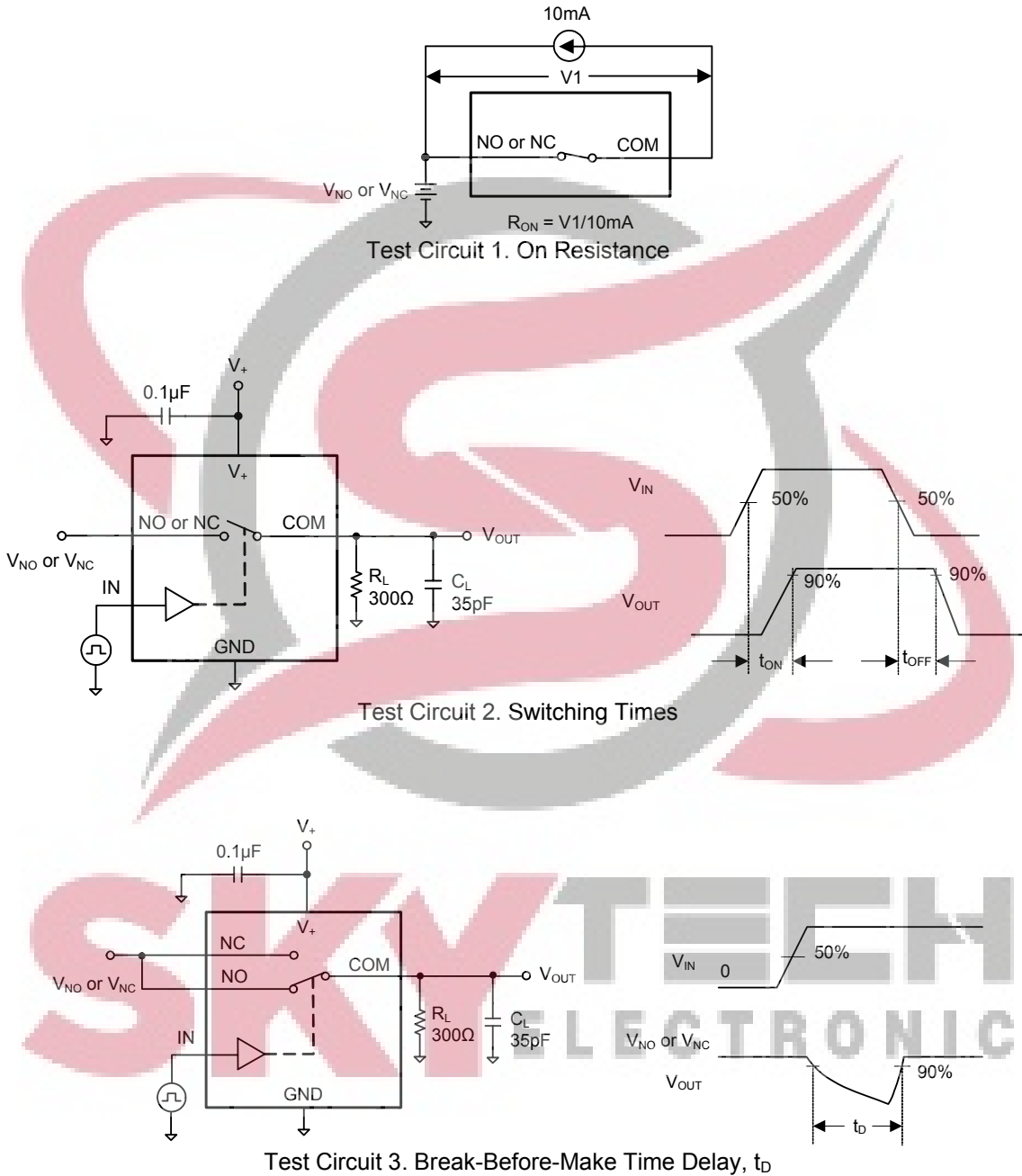

TEST CIRCUITS (Cont.)

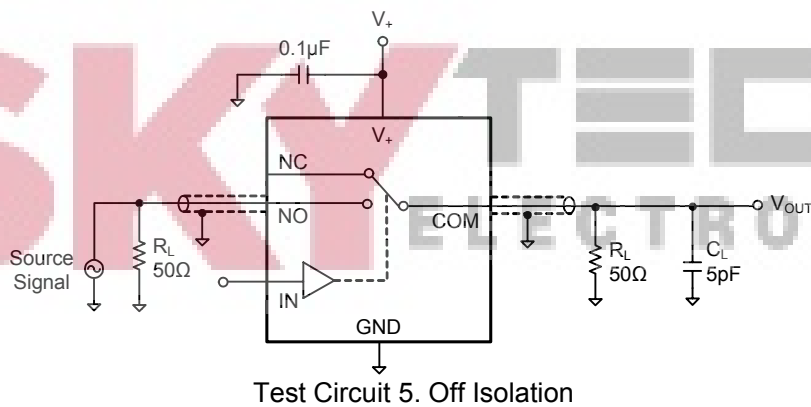
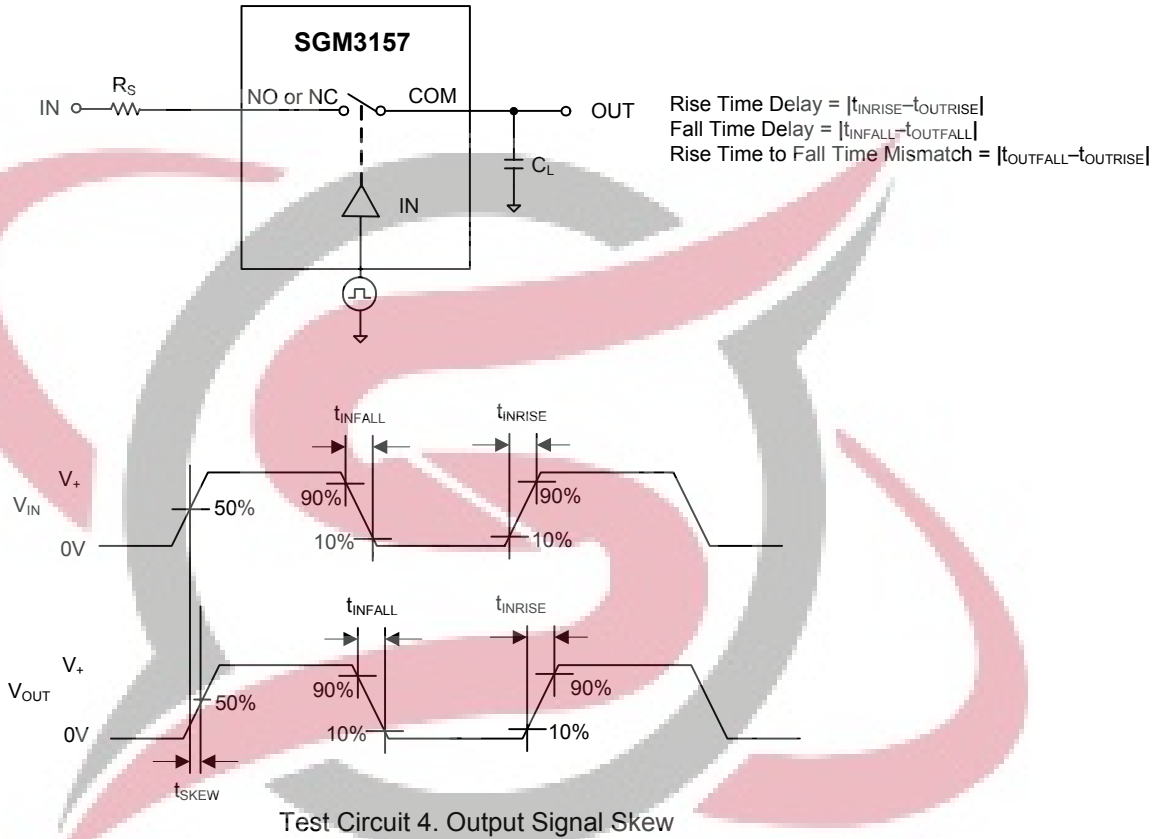

TEST CIRCUITS (Cont.)

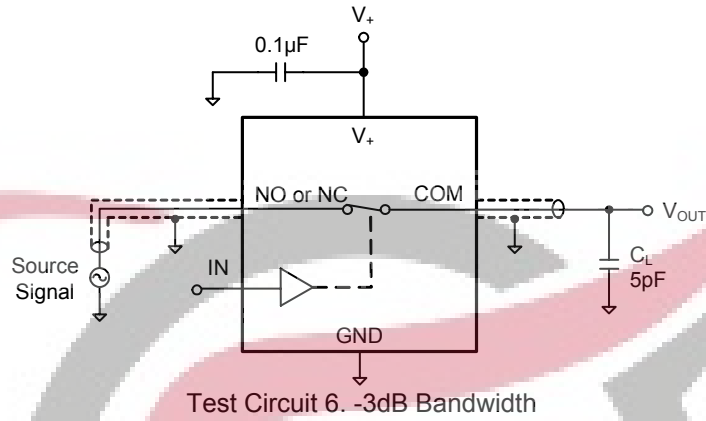

SKYTECH
ELECTRONIC

PACKAGE OUTLINE DIMENSIONS

SC70-6 / SOT-363

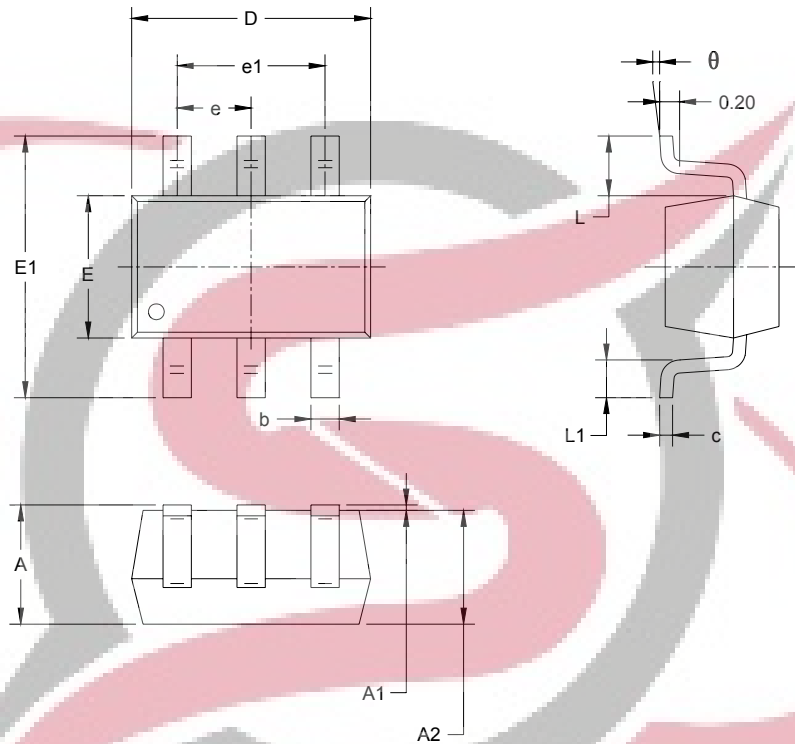

Symbol	Dimensions In Millimeters		Dimensions In Inches	
	MIN	MAX	MIN	MAX
A	0.900	1.100	0.035	0.043
A1	0.000	0.100	0.000	0.004
A2	0.900	1.000	0.035	0.039
b	0.150	0.350	0.006	0.014
c	0.080	0.150	0.003	0.006
D	2.000	2.200	0.079	0.087
E	1.150	1.350	0.045	0.053
E1	2.150	2.450	0.085	0.096
e	0.65 TYP		0.026 TYP	
e1	1.300 BSC		0.051 BSC	
L	0.525 REF		0.021 REF	
L1	0.260	0.460	0.010	0.018
θ	0°	8°	0°	8°



04/2010 REV. B. 3

SGMICRO is dedicated to provide high quality and high performance analog IC products to customers. All SGMICRO products meet the highest industry standards with strict and comprehensive test and quality control systems to achieve world-class consistency and reliability.

For more information regarding SGMICRO Corporation and its products, please visit www.sg-micro.com